



Sensors for motion control

Decentralised and smart monitoring of rotating machines



Systems for signalling and indication



Mini display with speed monitoring function for direct mounting on the sensor

On-site speed display with colour change (red/green)

Two adjustable limit values, each with its own switching output

- IO-Link enables parameter setting outside the danger zone
- Transmission of the current speed to the controller via IO-Link

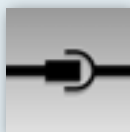
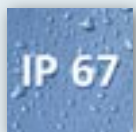
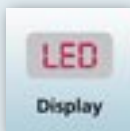

Transforms any sensor into a speed monitor

Whether inductive, capacitive or photoelectric sensor: This small device transforms any pulse-generating sensor into a speed monitor. The mini display with speed monitoring function is either screwed directly onto the sensor using an M12 connection or installed in the field. Two adjustable limit values, each with its own switching output, as well as a display with altering red/green indication signal if the current value is above or below the defined speed range.

The unit is conveniently set via IO-Link or using the buttons on the device. The speed value can also be transmitted to the controller via the digital communication protocol.

This makes the speed monitor plug an inexpensive and flexible solution for decentralised monitoring of conveyor belts, screw conveyors, fans, centrifuges, separators, etc.



Dimensions

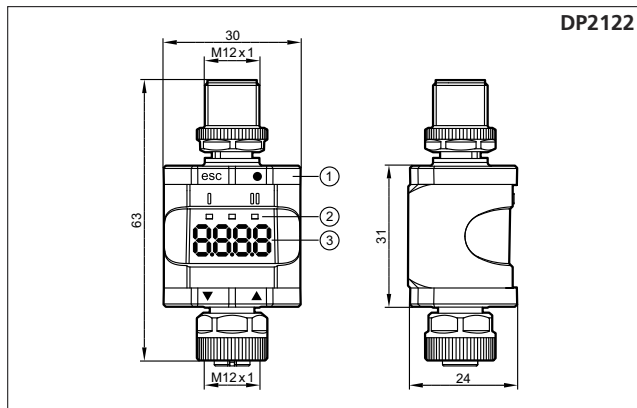

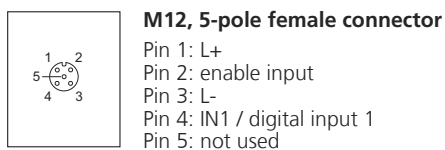
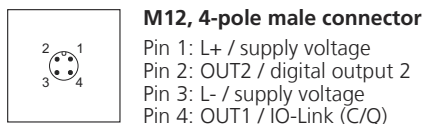

- 1) Push ring
- 2) LEDs
- 3) Display

Wiring diagram



Accessories

Type	Description	Order no.
	Mounting clip, robust design for use in harsh industrial environments	E89208
	1-port IO-Link master (for connecting IO-Link sensors to a PC via USB)	AL1060

Technical data

Mini display with speed monitoring function		Order no. DP2122
Nominal voltage	[V DC]	24
Input frequency	[Hz]	2000
Current consumption	[mA]	30...380 (24 V DC, full load)
Inputs		2 x digital
Outputs		2 x digital
Voltage range	[V DC]	18...30
Output function		NO / NC (configurable)
Current rating per output	[mA]	50 (pin 4) / 100 (pin 2)
Ambient temperature	[°C]	-25...60
Storage temperature	[°C]	-25...60
Protection rating		IP 67
Communication interface		IO-Link
Operation indication	LED	1 x green
Output indication	LED	2 x yellow
Connection		M12 connection

Applications

Especially in the field of conveying technology the speed sensors can be used in various applications, for example, to monitor belt conveyors or bucket elevators. Here they are typically used to monitor underspeed, blockage or standstill.

Advantages

The mini display incorporates the complete speed monitoring. The switch points and other parameters can be set directly on the display. In addition, IO-Link provides remote information about the current speed or the switch point and the configuration of important parameters such as the start-up delay time.

Operating principle

The sensor is damped by passing cams or other metallic targets and transmits the pulses to the display. On the basis of the time interval between the damping operations, the evaluation calculates the period duration or the frequency (actual rotational speed value) and compares it to the set switch point (preset value). The output is switched during the start-up delay and when the rotational speed exceeds the set switching value.

The mini display signals over- and underspeed and switch-off of the output.